

NOTES:

- 1. DIMENSIONS IN [] ARE INCHES
- 2. MATERIAL SBR/NR
COLOR: BLACK
50 SHORE A DUROMETER

REV	DESCRIPTION	DATE	BY	APP

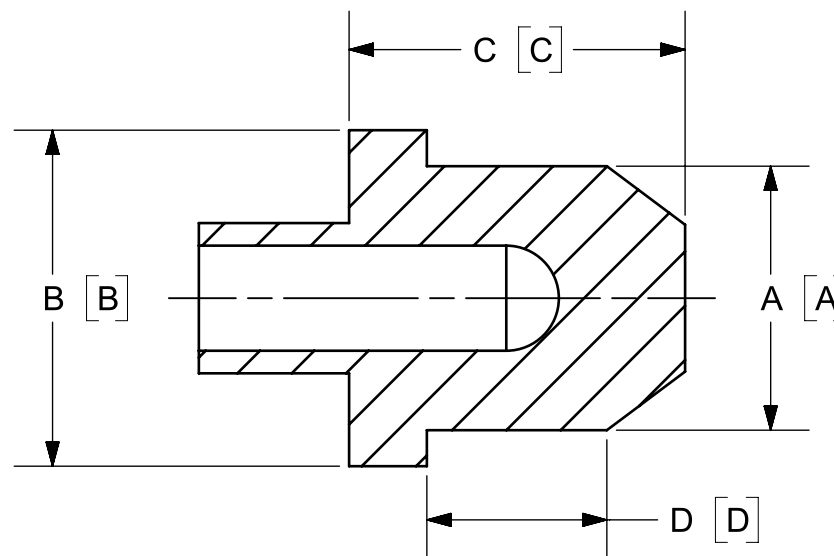
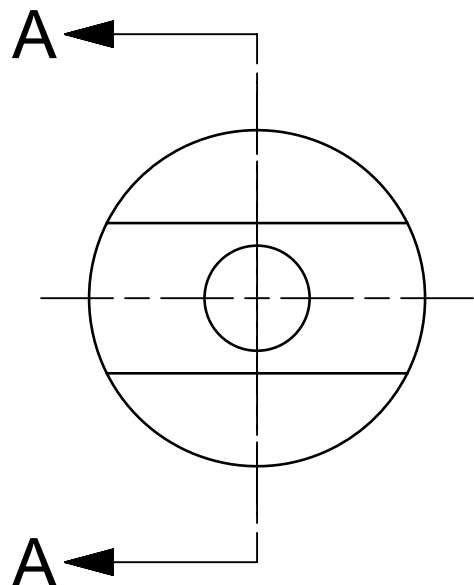

SECTION A-A



Sinclair & Rush

Global Manufacturer of Plastic, Rubber & Foam Components

SINCLAIR AND RUSH LTD.
19 LAKER ROAD,
ROCHESTER
KENT, ME1 3QX UK

WWW.SINCLAIR-RUSH.CO.UK

DIMENSIONS ARE IN INCHES

TOLERANCES:
(UNLESS OTHERWISE SPECIFIED)

RMA A3 COMMERCIAL

THIS DRAWING CONTAINS CONFIDENTIAL INFORMATION OF SINCLAIR AND RUSH LTD. AND IS NOT TO BE COPIED, USED OR, DISCLOSED TO OTHERS WITHOUT THE EXPRESS WRITTEN CONSENT OF SINCLAIR AND RUSH LTD.

ALL DIMENSIONS AND SYMBOLS CONFORM TO ANSI Y14.5



DRW	WMB	DATE	24-MAY-23
CK	GSG	DATE	25-MAY-23
APP	GSG	DATE	25-MAY-23

SCALE 2.5:1

RUBBER SEAL PLUG W/ TAB SIZE CHART

RSP CODE	PART NUMBER	A	B	C	D
RSP0470WT	652532	11.94 [0.470]	14.48 [0.570]	22.23 [0.875]	11.13 [0.438]
RSP0628WT	255033	15.95 [0.628]	19.05 [0.750]	28.60 [1.126]	17.48 [0.688]
RSP0828WT	985068	21.03 [0.828]	23.06 [0.908]	20.78 [0.818]	11.13 [0.438]

DESCRIPTION RUBBER SEAL PLUGS W/ TAB, UK TABLE REF

SIZE	A	SHEET	1 OF 1	PART / DRAWING NUMBER	CP4584	REV	0
------	---	-------	--------	-----------------------	--------	-----	---