

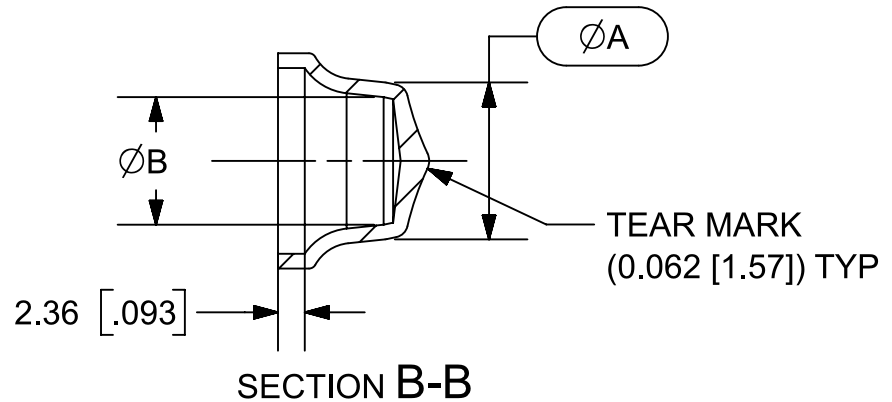

PART NAME	OD_A (mm)	ID_B (mm)
SR1	7.23	5.59
SR2	9.66	7.32
SR25	10.91	8.59
SR3	12.57	9.19
SR35	13.84	11.25
SR4	16.52	13.03
SR5	20.44	17.25
SR6	25.98	22.68
SR7	32.33	29.03

REV	DESCRIPTION	DATE	BY	APP

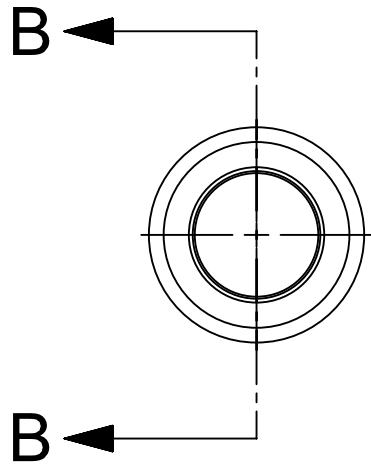

- NOTES:
1. DIMENSIONS IN [] ARE INCHES.
 2. DIMENSIONS INSIDE OVALS ARE INSPECTION DIMENSIONS.
ALL OTHER DIMENSIONS ARE REFERENCE.
 3. MATERIAL: FLEXIBLE PVC

	<h2>Sinclair & Rush</h2> <p>Global Manufacturer of Plastic, Rubber & Foam Components</p>		<p>SINCLAIR AND RUSH LTD. 19 LAKER ROAD, ROCHESTER KENT, ME1 3QX UK WWW.SINCLAIR-RUSH.CO.UK</p>				
	<p>THE VINYL DIP MOLDING PROCESS RESULTS IN VARYING WALL THICKNESS. WALL THICKNESS IS MEASURED AT SPECIFIED POINT ONLY.</p> <p>TOLERANCES: (UNLESS OTHERWISE SPECIFIED)</p> <p>DECIMALS .XX ±0.25 [±0.010]</p>		<p>THIS DRAWING CONTAINS CONFIDENTIAL INFORMATION OF SINCLAIR AND RUSH LTD. AND IS NOT TO BE COPIED, USED OR, DISCLOSED TO OTHERS WITHOUT THE EXPRESS WRITTEN CONSENT OF SINCLAIR AND RUSH LTD.</p>				
<p>ALL DIMENSIONS AND SYMBOLS CONFORM TO ANSI Y14,5</p> <p>THIRD ANGLE PROJECTION</p> 		DRW	JAB	DATE	20-JUN-19		
		CK	BPF	DATE	21-JUN-19		
<p>SCALE 1:1</p>		APP	BPF	DATE	21-JUN-19		
		<p>DESCRIPTION PLUS PLUG SERIES CHART DRAWING</p>					
SIZE	A	SHEET	2 OF 2	PART / DRAWING NUMBER	Plus_Plugs	REV	0